



NV 1142

# SERVICE RELEASE

motorcycles

## CATEGORY OF RELEASE:

No. N3/12

**NATURE OF RELEASE:** 750 Racer and 750 Formula Racer Conversion Kits and Components.

**MODELS AFFECTED:** 750 Commando (all Models).

**DISTRIBUTION:** Worldwide (General Distribution).

**EXPLANATION:** A range of conversion kits has now been made available to enable the use of certain Factory Racer and Formula Racer equipment in standard Commando models.

## CONTENTS SUMMARY

<i>Kit Number</i>	<i>Description</i>	<i>Page No.</i>
1	Engine Performance .. .. .	2
2	Carburetor Accessories .. .. .	5
3	Head Steady, Isolastic Mounts .. .. .	6
4	Handlebar and Controls, for use in conjunction with the listed Fairings, Screens, Seats, Brackets and Fuel Tanks. Oil Tank and Frame Modifications	4-11
5 } 6 } 7 }	Rear Set Footrest Kits 5 and 6 for the 750 Racer includes the Exhaust Pipes	12
	Rear Set Footrest Kits 5 and 7 for the 750 Formula Racer .. .. .	13
8	Exhaust Megaphone Equipment .. .. .	13
9	Norvil Single Disc Front Brake .. .. .	14
10	Norvil Double Disc Front Brake .. .. .	15
11	Conversion of Norvil Single Disc to Double Disc .. .. .	16
12	Front Mudguard .. .. .	16

The contents include a fully illustrated listing of individual components and assembly numbers, together with comprehensive "step by step" fitting instructions.

AUGUST 1972

## KIT NUMBER 1. ENGINE PERFORMANCE

1—061427	Cylinder head c/w guides.
2—061396	Inlet valve.
2—061397	Exhaust valve.
4 prs.—061398	Split valve collets.
4—061399	Valve spring seat.
1—063761	Triple "S" camshaft.
1—061425	Piston assembly L.H.
1—061422	Piston assembly R.H.
1—063608	Gasket set.

This kit must be fitted in its entirety to ensure achievement of the designed conditions and specified performance.

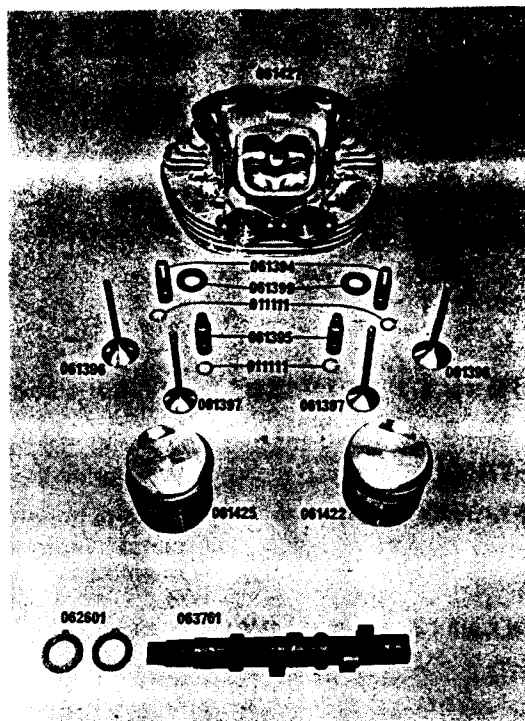

Illustration 1

## FITTING INSTRUCTIONS

### Dismantling Engine

Before attempting to dismantle the engine, clean the complete motorcycle most thoroughly in the area of the power unit to avoid the risk of dirt entering at any stage of dismantling or reassembly. The total strip and rebuild instructions for the standard motorcycle are contained in the new Commando Workshop Manual but are repeated in abbreviated form below, with areas differing from the standard procedure detailed in depth. For ease of handling the engine unit should be removed from the mounting plates as a unit so that it can be dealt with on the bench.

1. Remove the left footrest and brake pedal and allow these to hang on the cable.
2. Drain and remove the outer primary chaincase, alternator rotor nut and alternator stator. The stator can be left attached to the inner chaincase by the lead but disconnect the two connectors beneath the airbox and lever off the rotor.
3. Slacken off clutch adjustment, compress the clutch diaphragm spring (this requires tool 060999) and remove circlip.
4. Fit clutch hub tool 061015 and remove clutch centre nut and fit engine sprocket extractor tool 060941. Remove engine sprocket and lift entire engine sprocket - primary chain - clutch assembly away.
5. Flatten tab washers locking three bolts around crankshaft stub, remove the three bolts and lift off inner chaincase.
6. Remove rubber breather hose (near primary cover on early models; under rear of engine on 1972 and later).
7. Detach engine ground wire attached to lower left crankcase stud.
8. Remove fuel tank, ignition coils, carburetor top caps and withdraw slide assemblies. Remove exhaust pipes and upper Isolastic head steady.
9. Drain oil from oil tank and remove oil feed lines from boss beneath timing cover. Remove rocker oil feed pipe.
10. Disconnect the contact breaker lead wires and tachometer drive cable.
11. Slip a sturdy support (wood block or metal rod) between engine and lower frame tubes.
12. Remove bolts holding rear of engine to engine cradle so engine hinges on front Isolastic mount.
13. Loosen small bolts holding front engine mount. STEADY ENGINE and remove large Isolastic mount bolt, then the small bolts and lift out front Isolastic mount.
14. Engine is now free and can be lifted clear of frame on to workbench.

### Removing Cylinder and Cylinder Head

1. Remove rocker covers, carburetors and spark plugs. Slacken rocker adjustments.
2. Find five top bolts, two top nuts and three nuts in cylinder finning. By working in rotating order, slacken each half a turn at a time until all pressure has been released and remove.
3. Cylinder head should now be free (a few gentle taps with a soft faced mallet may be needed to free the head), lift off head and withdraw push rods.
4. Remove cylinder base nuts and lift cylinder clear. Carefully support pistons as cylinder comes clear to avoid damage to pistons and rods.
5. Remove piston circlips, gently heat pistons and gently press out wrist pins. DO NOT place side loads on connecting rods.
6. Wrap connecting rods with rag to avoid damaging them.

### Timing Side Dismantling

1. Remove contact breaker cover, contact breaker plate and fit draw-bolt tool 06-0934 to advance mechanism and remove mechanism.
2. Remove timing cover screws (note locations – three lengths used) and remove timing cover.
3. Remove oil pump (two nuts) and lift off pump.
4. Remove oil pump drive worm nut (left hand thread).
5. Remove cam chain tensioner.
6. Remove camshaft sprocket nut, and using tool 060941 remove camshaft sprocket. Place washer over camshaft end to avoid marking it.
7. Remove cam chain assembly (complete with both sprockets).
8. Use tool ET.2003 to remove small timing pinion. Take out triangular washer, key and oil seal.

### Separating the Crankcases

1. Remove all studs, screws, and the bolt holding cases together.
2. Tap a wooden bar into the inside of the drive side case to separate the cases.
3. Lift the drive side case clear (and collect the breather disc and spring from camshaft bush – pre 1972 models).
4. Withdraw the camshaft from timing side with its thrust washer (two on 1972 and later models).
5. Slide a suitable tube over the crankshaft end. Stand the crank and timing case on this tube and, using a light hammer and a wooden bar, tap the inside of the timing case to drive it off. (On 1972 later models, a roller bearing is fitted and disassembly is greatly eased).

**NOTE:** Although not part of the racing kit, Norton Villiers strongly recommends that any time a racing engine is disassembled, the connecting rods should be removed, and carefully inspected for cracks and signs of metal fatigue. If considerable mileage has been accumulated, it is wise policy to fit new connecting rods. In any case, FIT NEW BEARING SHELLS and con rod bolts. The nuts are of a self-locking design and can be used ONLY ONCE. Meticulous race preparation also calls for a crankshaft inspection – look carefully for cracks, damage and wear. Also inspect the connecting rod bearing journals for wear or scoring. These journals should also be "miked" to ascertain concentricity. Heavily scored or oval journals should be reground (see Workshop Manual).

### Reassembly of Engine

1. It is good practice to check the clearance for racing camshafts in older model (1968-71) crankcases. Reassemble the cases with only the camshaft 063761 in position (including, of course, the rotary breather and spring, thrust washers, etc.) and rotate the camshaft by hand. Carefully note that all the new cam lobes clear the inside of the crankcases, that the camshaft is free and does not bind in any position and has no excessive end-play.
2. It is also good practice to carefully check main bearings for excessive clearance and to replace them if necessary and, in any case, replace if considerable mileage has been accumulated. See Workshop Manual.
3. All parts should now be checked carefully for immaculate cleanliness and lightly oiled. A compound of "anti-scurf" molybdenum disulfide should also be available for treating heavily loaded parts such as cam lobes and tappets. The crankshaft should also be filled with clean oil.
4. Lightly oil the drive side bearing and mate the drive side case to the crankshaft (at bottom dead centre position to minimise possibility of damage to con rods. Rods should not be allowed to be scratched, gouged or bruised).
5. Insert the camshaft (with rotary disc and spring on pre 1972 models) into the drive side case. Place thrust washer onto camshaft (there are two tabbed thrust washers 062601 on 1972 later models. These must be assembled with tabs outwards and in proper slots, and the tabs must not be allowed to come out of proper position during later assembly).
6. Apply a thin coating of non-flaking jointing compound to one of the joint faces of the crankcases.
7. Oil the ball bearing, pass the timing side case over the crankshaft end, and mate the two case halves together.
8. Fit the case uniting studs, bolt, and screws and tighten.
9. Refit the timing side of the engine in reverse order of that described in "Disassembly" and by reference to Workshop Manual.

## Assembly of Pistons

1. Inspect cylinder bores. Obtain a new piston ring and place in the bottom of the cylinder (at a point below any ring wear), and measure the ring gap with feeler gauges. Reposition the ring in the centre and top of the bore, measuring the gap on each occasion. The measured cylinder bore wear is the subtracted difference between the first reading and each subsequent test – divided by 3. If the wear is more than 0.0015 in. the cylinder should be rebored. If the bore is new or in good condition, ensure the bore has a "glaze-break" roughened surface (at 45° pattern). Also ensure that there is no groove or "ring step" at top or bottom of bore.
2. Pistons 061425 and 061422 are made in "handed" sets – i.e., there are cutaways for valve clearance that prevent interchange of pistons. Pistons are marked on crowns.
3. Fit the corrugated expander scraper in the lower ring groove. This must not overlap. Then fit one thin ring over its upper edge and one thin ring over its bottom edge.
4. Fit the tapered ring into the middle groove with the word "top" stamped on it facing upward.
5. Fit the plain top ring in the top groove.
6. Repeat for other piston.
7. Lightly oil small end connecting rod bore. Heat gently one piston. Place in position on its respective rod and slide wrist pin into position. Locate the piston circlips.
8. Repeat for the other piston.
9. Assemble cylinder to crankcases in normal fashion (see Workshop Manual). Note that tappet locating plates 063092 must be fitted to accommodate increased lift of racing camshafts.

## Cylinder Head Assembly

1. The racer head is supplied bare, i.e. without rockers, valves, valve springs. The head must be assembled in the normal manner (see Workshop Manual).
2. This cylinder head 061427 is designed so that the proper valve clearances may be maintained between the valves themselves and the pistons. Only this head can be used when fitting "SS" or "SSS" cam to a standard engine.
3. The head is secured to the cylinder in the normal manner (see Workshop Manual). Valve are set to a clearance of .008 in. (0.020 mm) on the inlet side and .010 in. (0.025 mm) on the exhaust (cold). Using a short test bar, ensure further movement can be made to the valve, when the valve is held fully open at full cam lift – i.e. spring pack is not coil bound.

The engine is then re-assembled into the frame in the normal manner. However, to cope with the increased power and to improve handling for racing purposes, Norton Villiers offer an Isolastic mounting kit 061484 comprising a new head steady assembly and slightly modified internals for the front and rear main Isolastic mounts.

A full flow oil filter was incorporated as standard equipment on machines subsequent to engine number 208576, and is fully illustrated in the 1972 Commando Model Parts List. We would recommend incorporation into the return oil line on machines used for racing purposes prior to this number. Two mounting bolt holes only are required in the rear engine mounting plate.

## Technical Data — Engine Performance Kit Fitted

Piston compression ratio	.. .. .	10.25:1.
Inlet valve material	.. .. .	Chrome silicon steel. Stem hard chrome plated.
Inlet valve diameter	.. .. .	1.610 in. (41 mm).
Exhaust valve material	.. .. .	Nimonic 80A. Stem hard chrome plated.
Exhaust valve diameter	.. .. .	1.310 in. (33.3 mm).
Inlet valve guide and seat material	.. .. .	Aluminium bronze or austenitic cast iron.
Exhaust valve guides and seat material	.. .. .	Aluminium bronze.
B.H.P. at sea level: 750 Racer	.. .. .	70 at 6,500 r.p.m.
750 Formula Racer	.. .. .	73 at 7,000 r.p.m.
Ignition setting: 28° B.T.C.	.. .. .	(31° B.T.C. with Boyer transistorised ignition).



## KIT NUMBER 3. ISOLASTIC MOUNTING HEAD STEADY ASSEMBLY

The kit contains the following items:

1—061484 Head steady assembly. (Illustrated with Kit number 2)

### FITTING INSTRUCTIONS

Dismantling original parts:

1. **Remove seat** after slackening large knurled side knobs, and disconnect battery at fuseholder.
2. **Remove fuel tank** – disconnect fuel lines at taps. Remove front securing nuts and collect metal and rubber washers. Dependent on model, release rear fixing band, bolts or cross strap and bolts.
3. **Remove existing head steady** – take nuts off 2 studs and flexible mountings and lift off side plates. Remove rubber mountings from frame. Remove socket screws and lift main steady plate away from cylinder head.

#### Fitting new parts

The new steady comes as a complete assembly 061484 but with extra shims to adjust total side play to the ideal figure of 0.010 in. (0.25 mm).

1. Offer new assembly into position and loose assemble socket screws into head.
2. Fit long bolts through rear holes in triangular plate, fit tubular spacer and thread bolts loosely into threaded frame bosses.
3. Fit front tube spacer and fit 2 short bolts loosely.
4. Fit clamp over small frame tube and secure with small socket screws.
5. To ensure self alignment, tighten all bolts progressively.
6. Before shimming the headsteady, main front and rear Isolastic mountings must be shimmed to an ideal clearance of 0.010 in. (0.25 mm) as detailed in Service Release N3/10 or latest Workshop Manual. Now shim new head steady to same figure by recommended method. Suitable shims are enclosed with kit.

### MODIFICATIONS TO ISOLASTIC MOUNTS

1. **Front:** Disassemble front Isolastic mount (see Workshop Manual). Have available on additional part number 061226 bush (tube bonded to rubber) and 2 part number 063538 spacers.
2. Insert 1 061226 bush into one end of tube. Invert tube. Find part number 061277 (aluminium tube with 2 rubber buffers). Remove the buffers and fit (1 each) to the new 063538 spacers. Discard long aluminium tube.
3. Drop one of the 063538 spacers into the mounting tube. Insert another 061226 bush into the tube (as in number 2) and push down until it abuts the spacer. Drop the other 063538 spacer on top of the second bush and insert the last 061226 bush.
4. Assemble and mount normally as in Workshop Manual instructions.
1. **Rear:** Remove rear Isolastic unit. Have available 1 additional 061227 bush and 2 063480 spacers.
2. Remove bushes and spacers from tube. Remove rubber buffers from these spacers and assemble onto the new 063480 spacers.
3. Insert 1 061227 bush into end of tube. Invert tube.
4. Drop in 1 063480 spacer. Insert 2 061227 bushes and push down until they abut the spacer. Drop in the other 063480 spacer and insert the last 061227 bush.
5. Reassemble normally. Follow Workshop Manual.

## KIT NUMBER 4. HANDLEBAR AND CONTROLS, FAIRINGS, SEATS, FUEL AND OIL TANKS

### Handlebar and Controls

- 1—063850 Handlebar assembly L.H.
- 1—063851 Handlebar assembly R.H.
- 1—016658 Quick action twist grip.
- 1—023740 Dummy grip.
- 2—063479 Fork tube top bolt.

With the exception of parts number 063479, these items are illustrated in kit number 2.

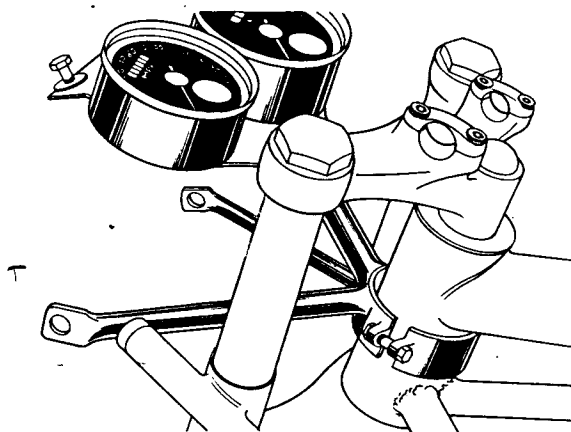

Illustration 3

### FITTING INSTRUCTIONS

These fitting instructions do not apply to 1972 and later models fitted with Norton Lockheed disc brake equipment.

1. **Remove headlamp** fixing bolts and leave lamp hanging on wiring harness.
2. **Remove fuel tank** – disconnect fuel lines at taps. Remove front securing nuts and collect steel and rubber washers. Dependent on model, release rear fixing band, bolts or cross straps and bolts.
3. Part the switch clusters, clutch and brake controls and leave hanging on leads/cables. Slacken and slide off twistgrip and air control still attached to cables.
4. Remove clamps and handlebars. Replace clamps and secure.
5. Remove bulbholders with bulbs from tachometer and speedometer and leave hanging on lead. Release speedometer and tachometer cables. –
6. Slacken and lift fork tube chrome top bolts, hold bolts and release damper rods, life instruments clear in aluminium pods.
7. Slacken bottom yoke pinch bolts.
8. Remove front wheel.
9. Attempt to pull fork legs down, free of yokes. If necessary “break” taper between fork tubes and top yoke by replacing top chrome bolts to half thread engagement and striking with hide hammer. Remove chrome bolts and lift away fork leg assemblies as a pair with front fender still attached.
10. Remove top shrouds with headlamp brackets by untabbing stem nut and striking centrally on bottom yoke. Collect shrouds and 3 ‘O’ rings from each side.

Having dispensed with existing headlamp brackets it is necessary to fit the instrument/fairing bracket from the fairing kit which incorporates revised headlamp brackets. Proceed as follows:

11. Offer both fork legs through bottom yoke leaving room to insert clip-on bars.
12. Place clip-on handlebars 063850/063851 over main tubes with clamps rearward and bars sloping downward.
13. Lay headlamp attached to harness central over top yoke so that harness is not trapped.
14. Slide both fork legs up through bottom yoke to engage top yoke tapers.
15. Reconnect and tighten damper rods to new alloy top nuts complete with washers. (The nuts are shorter since instrument pods are dispensed with). Oil remains in fork legs thus top nuts may now be screwed home finger tight.
16. Assemble speedometer and tachometer to fairing/headlamp bracket 063750 (750 Formula Racer) 063938 (750 Racer) tachometer to left side.
17. Clamp the bracket with instruments to frame steering head tube as shown in illustration 3. This bracket serves as headlamp, instrument and fairing mounting. Position clamp for height midway between top and second frame top tubes and align bracket and instruments visually with frame top tube. Tighten hardware so that clamp is pulled up evenly to bracket.
18. Route cables to avoid trapping. Cables should be draped forward and splayed below and to each side of headlamp ‘V’ brackets.
19. Fit headlamp to ‘V’ bracket and secure with existing bolts less spacers. If necessary open bolt holes in bracket.
20. Fit airlever on inboard end of left clip-on handlebar. Refit clutch control to left switch cluster and route cable without tight bends.
21. Refit twistgrip to right bar and matching dummy grip to left bar.
22. Reconnect speedometer and tachometer cables and refit instrument bulbs and bulbholders routing cables and leads between headlamp ‘V’ bracket.
23. With the forks visibly aligned, tighten adjustment points in the following order: alloy top bolts, main fork stem nut, bottom yoke pinch screws. *Do not* overtighten the stem nut. Tap over the locking tab on 1971 and later models.

**INSTRUCTION — CONVERTING STANDARD OIL TANK TO SUIT RACING TANKS AND SEATS  
1971 AND LATER MODELS**

The froth tower portion of existing oil tank must be re-formed to provide clearance for right hand rear of 750 Racer or 750 Formula Racer fuel tanks and seats. Oil tanks in standard and modified condition are shown in illustration 4.

1. Slide breather tube off stub on tank froth tower.
2. Drain oil tank into a suitable receptacle.
3. Remove large hexagon headed filter, releasing oil pipe banjo from rear of oil tank.
4. Release hose clamp and pull return oil line away from tank.
5. Remove long bolt and washer securing tank to battery tray.
6. Remove nuts and washers securing front and rear tank mounting brackets to flexible mountings.
7. Lift tank up at front whilst pulling out gently to right side.

Place tank on a block supporting on inboard surface so that oil pipe stub is not bearing any weight during next operation. It is now necessary to re-form tank inwards in area shown. This is achieved by cutting out a 1/2 in. (12.7 mm) fillet of metal behind the top seam lip, using a mallet to close up inwards and re-welding. Alternatively, it will be found that this area of the tank can be deformed quite readily by amateur panel beating. This is achieved by the use of a cross pein hammer along behind the top seam of the tank at the froth tower. When a distinct "crease" has been made, using a block of wood longitudinally outboard of the top seam to avoid unsightly hammer marking, hammer the block and the seam will fold in with very little problem.

The tank must be well cleaned and drained before re-welding, to remove all traces of metal cuttings and oil deposits. Check the top tank seam to ensure this has not been damaged during re-forming.

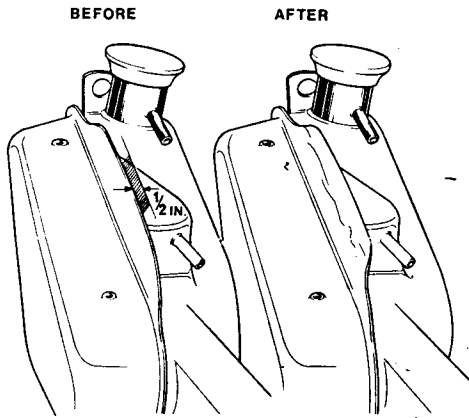

Illustration 4

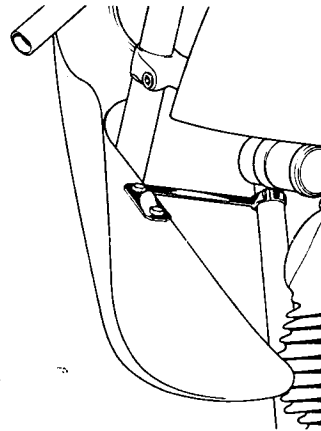

Illustration 5

**FAIRING (750 RACER)**

- 1—063935 Fairing shell.
- 1—063936 Screen.
- 7—011005 Bolt.
- 7—021001 Nut.
- 14—000039 Washer.
- 1—063937 Headlamp cover.
- 5—011005 Bolt.
- 5—021001 Nut.
- 10—000039 Washer.
- 1—063938 Fairing front fixing bracket c/w clamp.
- 1—063939 Side fixing bracket L.H. c/w clip.
- 1—063940 Side fixing bracket R.H. c/w clip.
- 4—060359 Bolt.
- 4—014999 Washer.
- 4—060648 Rubber.
- 4—000012 Washer.
- 4—062240 Nut.

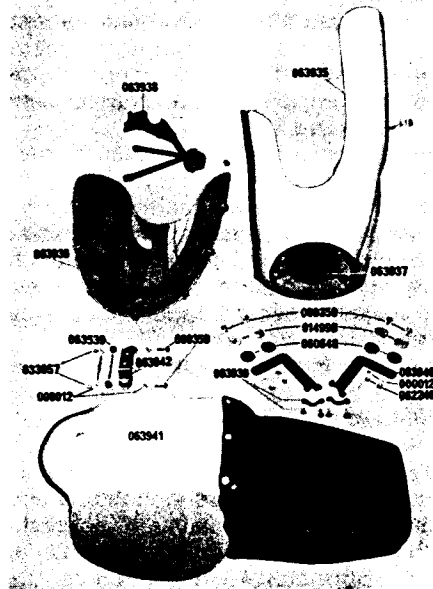

Illustration 6



## FITTING INSTRUCTIONS

This kit is only useable in conjunction with clip-on handlebars and ideally with new tank, tall fairing and seat and rear footrests (Kits 5 and 6). The following instructions assume the fitting of these components:

1. Fit left hand bracket 063939 to frame downtube as in illustration 5. Secure with clamps and bolts.
2. Fit right hand bracket 063940 to frame downtube and secure with clamp and bolts (060359).
3. If not already fitted, fasten headlamp "window" 063937 to fairing. If hardware will not enter easily, *DO NOT* force. Open out holes with hot iron or with great care using small round file. Fit screw, plain washer, rubber washer to window, through glass fibre and secure with plain washer and nut.
4. Place fairing 063935 loosely into position over studs on tachometer bracket 063938 and place on large washer and self-locking nuts finger tight.
5. Lift sides of fairing to brackets on frame downtubes and loose assemble bolts with large washers 014999 from glass fibre side, interposing rubber washers 060648 between glass fibre and bracket. Fit washer 000012 and nuts 062240 at bracket side.
6. Check for clearance between fairing and other parts and ease with coarse file if necessary.
7. Tighten all hardware.
8. Attach screen 063936 with screws through plain washer, rubber washer, screen, glass fibre and washer into nut. *DO NOT* force – if necessary open holes with hot iron or small round file.
9. Positive lockstops are not provided with this assembly. Local provision should be undertaken to suit individual rider requirements.

## SEAT AND REAR FAIRING (750 RACER)

- 1—063941 Seat rear fairing assembly.
- 1—063942 Rear bracket.
- 2—060359 Bolt.
- 2—063539 Spacer.
- 4—000012 Washer.
- 2—033057 Nut.

*These components are included in the preceding illustration which contains also the 750 Race fairing.*

## FITTING INSTRUCTIONS

The seat and tail fairing can only be fitted in conjunction with the racing fuel tanks. Similarly seat and tail fairing can be fitted only after oil tank modifications as illustrated in these instructions.

1. Remove front bolt and washer from tail lamp fairing, and shorten as shown in illustration 7.
2. Attach Dzus bracket to Dzus plunger on rear of seat fairing.
3. Place a slave bolt to hold front end of frame-to-fender clip at rear loop.
4. Using spacers 063539 between Dzus bracket 063942 and fender, bolt rear end down by slave bolt, spot and drill fender, bolt down front of bracket and spacer. See illustration 8.
5. Splay out front hooks of new seat 063941 for best engagement to frame when pushed fully forward.
6. Fit seat and fairing 063941 and secure with half a turn on slotted Dzus plunger.
7. Remove redundant seat knob and special bolts and replace by hexagon bolts and nuts (not supplied) to secure suspension unit tops.

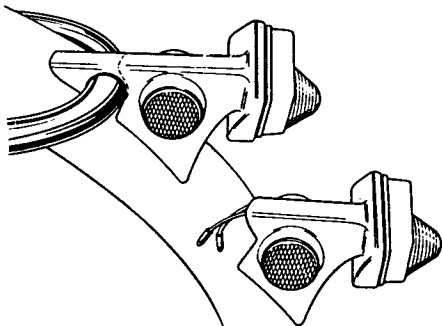

Illustration 7

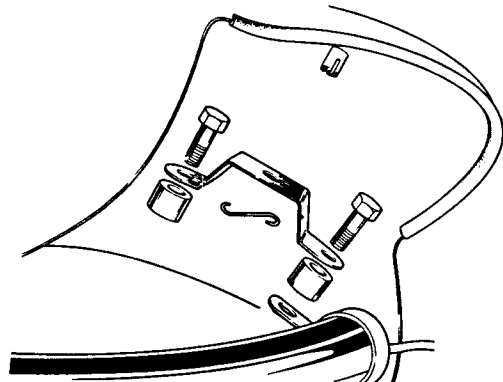

Illustration 8

## FRONT FAIRING, FRAME MODIFICATIONS AND SEAT FAIRING (750 FORMULA RACER)

- 1—063714 Fairing shell.
- 1—063715 Screen.
- 6—011005 Fixing bolt.
- 6—021001 Nut.
- 12—000039 Washer.
- 6—NMT272 Rubber washer.
- 6—22401 Spring washer.
- 1—063716 Fairing centre section.
- 4—011005 Bolt.
- 4—021001 Nut.
- 4—000039 Washer.
- 1—063750 Fairing front fixing bracket c/w clamp.
- 2—060359 Bolt.
- 2—000012 Washer.
- 2—060648 Rubber washer.
- 2—014999 Washer.
- 2—062240 Nut.
- 1—063749 Side fixing bracket L.H. c/w clip.
- 1—063748 Side fixing bracket R.H. c/w clip.
- 4—060359 Bolt.
- 4—014999 Washer.
- 4—000012 Washer.
- 4—062240 Nut.
- 1—063711 Seat and rear fairing assembly.



Illustration 9

This equipment should only be fitted as an entirety and in conjunction with the 750 Formula Racer exhaust system, etc. Since these components are wholly intended for racing purposes, it is assumed that the motorcycle is already semi-race prepared, devoid of all road equipment and that the existing front fender, fuel tank, seat and rear fender have been removed.

Note that once the frame has been converted in accordance with these instructions, it cannot revert to standard specification.

### FITTING INSTRUCTIONS

1. Fit clip on handlebars as Kit 4 which includes fitting the front fairing bracket.
2. Fit 750 Formula exhaust system as Kit 8.
3. Cut and weld rear frame loop to dimensions and configuration shown in Illustration 10. The frame rear loop tubing material is BS.980—CDSI. This is necessary to accept seat and seat fairing whilst providing adequate tyre clearance.

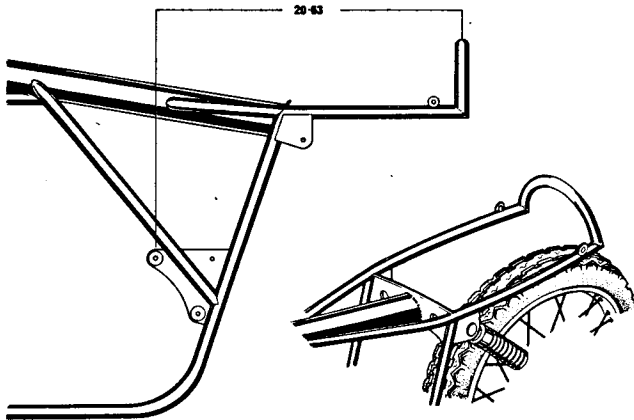

Illustration 10

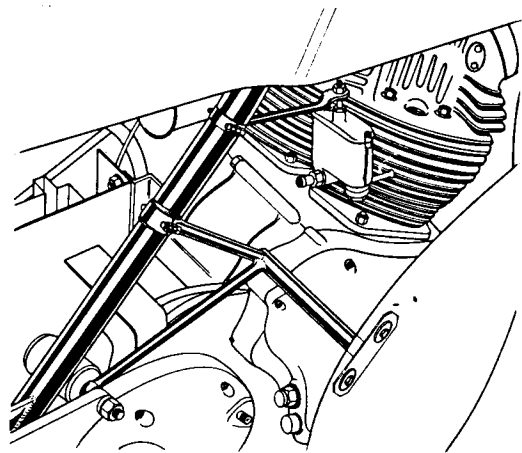

Illustration 11

With loop rewelded at 90° as shown, make up and weld in gusset plate outboard of tubes as shown. At a later stage these will be marked and drilled to accept seat fairing screws and provide pivots.

4. Using rubber adhesive stick front fairing bracket rubber washers 060648 to the front plate on the bracket (063750).
5. Mount the two fairing side brackets 063748/063749. These locate by clamps to sloping frame rail and over rear mounting stud replacing spacer inboard of footrest mounting plates.
6. Lift front fairing 063714 into position over front wheel and past fork legs, lowering into correct position. Great care is needed to avoid damage to finish.
7. Locate fairing temporarily by use of a single bolt through front and a single bolt through each side bracket.
8. Place the bottom panel 063716 in position with the forward "point" laying over the main fairing. Secure with screws, nuts and washers.

9. Check for clearance between exhaust pipes and fairing and fork tubes and fairing and provide extra clearance by filing as necessary.
10. Secure the fairing by 4 side and 2 front nuts, bolts and washers. Use large diameter washers 014999 under bolt heads 060359 against glass fibre, rubber washers 060648 between glass fibre and brackets, and secure with small washers 000012 and nuts 060359.
11. Fit screen 063715 to fairing – use screws with small steel washers and rubber washers against screen, plain washers and nuts from behind. *DO NOT* force if screws are hard to fit. Use a hot iron or fine round file with care to open out holes.
12. Make up and fit lockstops.
13. Lay seat with tail fairing 063711 in position, centre pop through side holes into gusset plates welded to modified frame loop, drill and secure. The seat and tail can be pivoted for access to oil filler cap.

## FUEL TANKS (750 RACER AND 750 FORMULA RACER)

- 1—063708 (6 imp. gal.).
- 1—063709 (5 imp. gal.).
- 1—063710 (3½ imp. gal.).
- 1—060498 Rubber band.



Illustration 12

### FITTING INSTRUCTIONS

Three capacities of tank are available. They are 3, 5 or 6 Imperial gallons. None of these tanks can be fitted without changing the seat, fitting tail fairing and modifying oil tank as described in these instructions. Assuming standard oil tank has been modified and that seat has been removed:

1. **Remove fuel tank** – disconnect fuel lines at taps. Remove front securing nuts and collect metal and rubber washers. Dependent on model, release rear fixing band, bolts or cross strap and bolts. Lift tank clear.
2. Prepare new tank for fitting by transferring tunnel sponge rubber pad from old tank to new and affixing with rubber cement. Place set of rubbers over front studs. Screw fuel taps with sealing washers into new tank bosses – reserve tap to right side.
3. Place tank loosely in position and before securing, check for points of foul. On individual models, it may be necessary to dress the front of tank at steering head tube of frame, at the right hand rear near the frame top tubes and oil tank and pack if necessary with additional rubbers. If any foul is detected at engine head steady, additional rubber packing is necessary between tunnel and frame.
4. Secure tank at front by large steel washer and one rubber washer beneath front bracket and at rear by a single flexible fixing band from peg to peg beneath frame tubes.
5. Reconnect fuel lines to taps and fit new Norton decals.

## KIT NUMBERS 5, 6 AND 7

### REAR SET FOOTREST KITS

#### Kit Number 5

- 1—063498 Pivot lug R.H.
- 1—015042 Bolt — pivot lug.
- 1—063568 Pivot lug L.H.
- 1—015062 Bolt — pivot lug.
- 1—063481 Pivot lug spacer.
- 2—28736 Bolt — pivot pin.
- 2—024001 Nut — pivot pin.
- 2—034002 Spring washer.
- 2—063495 Footpeg.
- 2—063500 Footpeg lug.
- 1—063671 Brake pedal.
- 1—063484 Adjuster lug — brake pedal.
- 1—063482 Stop lug — brake cable.
- 2—015042 Bolt.
- 1—013051 Adjuster screw.
- 1—023004 Locknut.
- 1—063551 Rear brake cable.
- 1—063944 Gearchange lever.

#### Kit Number 6

- 1—063853 Footrest plate L.H.
- 1—063829 Footrest plate R.H.
- 4—063512 Spacer tube.
- 4—015090 Bolt.
- 4—035000 Washer.
- 4—025001 Nut.

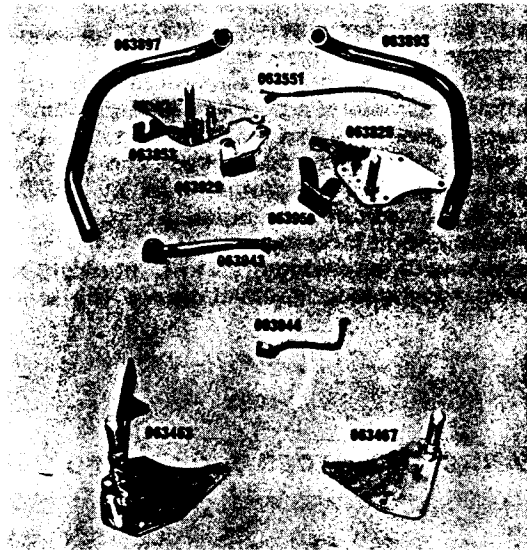

Illustration 13

- 1—063929 Silencer Mounting bracket R.H.
- 1—063959 Silencer Mounting bracket L.H.
- 1—063943 Kickstart crank assembly.
- 1—063897 Exhaust pipe R.H.
- 1—063893 Exhaust pipe L.H.

#### Kit Number 7

- 1—063467 Footrest plate L.H.
- 1—063463 Footrest plate R.H.

### REAR SET FOOTREST KIT NUMBERS 5 WITH 6 (750 RACER)

A reverse action camplate is available separately under part number 040578E. These two kits must be used together to complete the footrest conversion.

#### FITTING INSTRUCTIONS

1. **Remove both side panels** for ease of handling.
2. **Remove entire exhaust system** — release lockring tab washers and unscrew finned lockrings. Release mufflers from rear flexible mountings and lift away both exhaust pipes with mufflers attached.
3. **Release rear brake cable** at both ends and retain fittings. Disconnect rear stop light switch.
4. **Removing footrest mounting plates.** Disconnect the Zener Diode and earth lead from the right footrest plate. Remove footrest mounting plates complete with footpegs, rear brake pedal, etc. and collect bolts, nuts, washers and spacers for re-use with new footrest sets. Note that nuts on rear mounting stud are self locking and may be extremely tight. If necessary, prevent stud from turning by taking motorcycle off stand and placing weight of rider on seat area.
5. **Remove gear pedal.**
6. **Remove kickstarter** after taking out pinch bolt completely.

Commence assembly of new rear set footrests as follows, starting with the right side:

1. Drill  $\frac{1}{4}$  in. (6.35 mm) clearance hole in the mounting plate. Refit large diameter spacer over main mounting stud followed by right footrest mounting plate. Fit 2 bolts with washers through plates and locate spacers over bolts behind. On lower bolt fit also wire loop support to keep oil lines clear of swinging fork. Fit original nuts and washers to these bolts and to main mounting stud and tighten. Refit and reconnect the Zener Diode and earth lead utilising the hole drilled above.
2. Fit new length gear pedal 063944 facing rearwards and position to suit rider preference. Replace the indicator if required. If reverse action camplate preferred see separate instruction sheet.
3. Change over kickstart pedal, rubber, plain and spring washer and nut from displaced kickstart crank to new (063943). Locate new crank on suitable spline to clear gear pedal and give maximum swing, fit pinch bolt and tighten.

Commence fitting left side footrest group:

4. Refit large diameter spacer over main mounting stud, followed by left footrest mounting plate complete with fittings. Fit 2 bolts with washers through plates and locate spacers over bolts behind. Fit original nuts and washers to both bolts and main mount stud and tighten.
5. Assemble both new exhaust pipes 063897/063893 into the mufflers with clips loosely fitted. Using new sealing rings and tab washers assemble the finned lockrings to the cylinder head and holding the exhaust in the best position tighten fully. Locate each muffler with new chromed forked bracket (063929/063959) attached securely, to the flexible mounting and secure with nuts and washers. Tighten both muffler clips.
6. Fit the new rear brake cable 063551 to the abutments on the mounting plate and swinging arm, reconnect both ends with existing fittings and adjust the brake.
7. Refit battery and replace panels.

## REAR SET FOOTREST KIT NUMBERS 5 WITH 7 (750 FORMULA RACER)

A reverse action camplate is available separately under part number 040578E.

### FITTING INSTRUCTIONS

This kit is for use only with the current siamesed and megaphoned 750 Formula exhaust system. For twin exhaust pipes and either megaphones or mufflers, the 750 Racer footrest kit is recommended. The dismantling sequence is the same as for Kits 5 and 6. Assembly is similar except that there is no provision for mounting twin exhaust systems.

#### Fitting Reverse-action Camplate. Part number 040578E

1. See Workshop Manual section concerning removal of primary drive/clutch assembly. Remove clutch assembly from mainshaft end, pry off steel sleeve, and remove circlip from mainshaft. Drain oil from the gearbox.
2. Remove outer cover by releasing clutch cable, taking off shift indicator, kick starter, and screws. Using gear shift lever as handle, pull off cover.
3. Remove inner cover by removing ratchet plate and spindle, all clutch operating mechanism, mainshaft nut, and all nuts fixing cover. Tap lightly, if necessary, and pull off.
4. Remove internals by removing low gear pinion from mainshaft, unscrewing shifter fork spindle, removing the shifter forks and clutch push rod. Remove the mainshaft complete with gears and pull layshaft assembly out complete.
5. Remove dome nut with plunger and spring. Remove two bolts and withdraw camplate and quadrant.

#### Refitting the Camplate

1. Fit the shift quadrant with bolt and washer. Lift the outboard end of quadrant so that the fork end aligns with the top stud securing the cover. Slip in the camplate and loosely assemble detent plunger, spring and dome nut. Holding quadrant in position, position camplate so that smooth edge faces out and detent plunger engages last notch at bottom. Engage teeth of camplate and quadrant and secure camplate with bolt and washer. Secure detent plunger dome nut.
2. Fit the mainshaft with third gear on the shaft.
3. Fit mainshaft second gear with shifter fork engaged. Fit the projection on the fork into camplate and fit mainshaft first gear.
4. Fit the layshaft with gears assembled and shifter fork in position. Engage shifter fork projection in camplate, and slip layshaft into final position in its bush.
5. Line up the shifter forks, insert the spindle, and tighten. Fit layshaft first gear.
6. Follow Workshop Manual to fit gearbox inner and outer covers and to reassemble clutch and primary drive.
7. Note that the rear set kit shift pedal is reversed from normal position.

## KIT NUMBER 8. EXHAUST MEGAPHONE EQUIPMENT (750 FORMULA RACER)

1—063705 Megaphone Exhaust system complete.

### FITTING INSTRUCTIONS

This exhaust system is purely for road racing purposes. It is not suitable for any other purposes. In order to fit this system it is assumed that motorcycle is already prepared and less centre and side stands.

1. Loosen bottom crankcase to engine plate bolt and withdraw.
2. Withdraw left exhaust from siamesed system.
3. Take megaphone half of exhaust system, place sealing ring in right exhaust port and tab washer over captive lockring. Pass megaphone under engine and gearbox so that megaphone protrudes up from right side. Engage lockring to right exhaust port and finger tighten.
4. Place sealing ring in left exhaust port and place tab washer over captive lockring, on left exhaust pipe. Enter left pipe into right, at same time screwing lockring loosely into left exhaust port.
5. Replace front crankcase bolt through brackets on both exhausts, engine plates and crankcases. Tighten completely.
6. Tighten both lockrings and before securing tab washers, check exhaust to frame clearance to a minimum of  $\frac{1}{8}$  in. (3.175 mm). If necessary relieve locally to provide sufficient clearance.
7. Hold megaphone bracket against right hand rear engine plate to rear of gearbox casing. Spot through bracket hole to engine plate, drill and secure with bolt and self-locknut. On 1972 and later models, use the lower bolt of the oil filter assembly.
8. Re-check exhaust clearance to frame, finally tighten lockring and tap over tab washer.

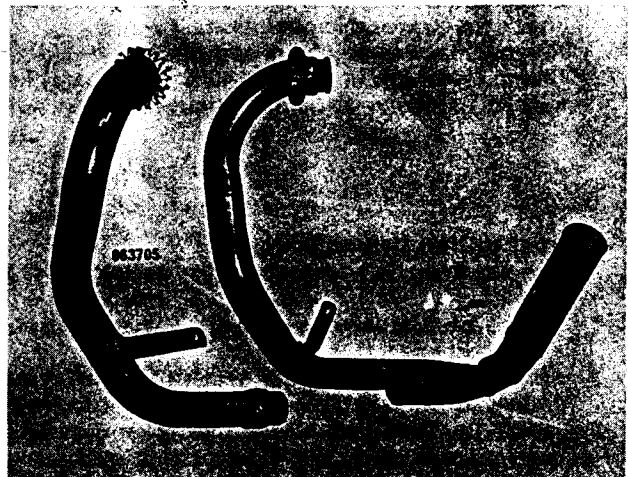

Illustration 14

## KIT NUMBER 9. NORVIL SINGLE DISC FRONT BRAKE

The kit contains the following items : (but must be fitted in conjunction with the racing front fender kit (12).

- 1—063701 Front wheel assembly.
- 1—063849 Disc.
- 1—063468 Hub – disc adaptor.
- 6—014060 Bolt.
- 6—024001 Nut.
- 12—000011 Washer.
- 1—063469 Disc retainer.
- 4—063471 Disc retainer washer.
- 4—011002 Disc retainer screw.
- 1—063476 Wheel spacer R.H.
- 1—063474 Wheel spacer L.H.
- 1—063547 Fork slider R.H.
- 1—063930 Caliper.
- 1—015100 Bolt.
- 1—015080 Bolt.
- 2—025001 Nut.
- 4—035000 Washer.
- 1—063949 Master cylinder.
- 1—063958 Hydraulic hose.
- 1—060362 Front wheel spindle.
- 1—060361 Front wheel spindle nut.

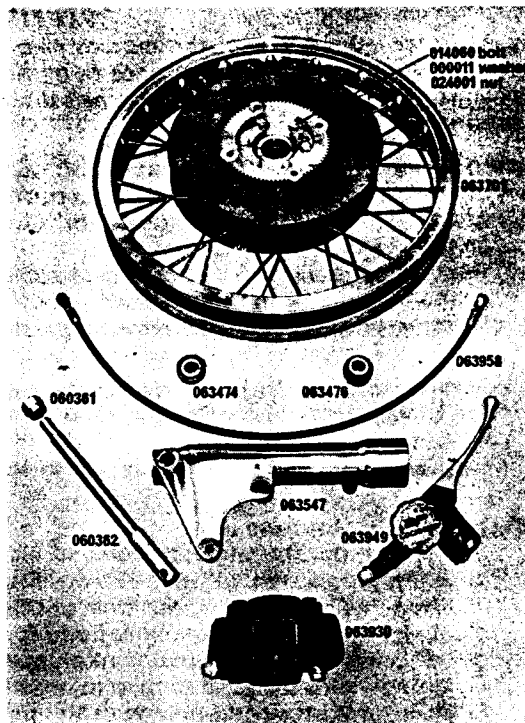

Illustration 15

### FITTING INSTRUCTIONS

1. Remove front wheel, front fender, and all front brake hardware (including handlebar lever).
2. Drain oil from right fork leg.
3. Slacken lower yoke pinch bolt (right side).
4. Unscrew chrome top nut 3–4 turns, use soft spacer to protect finish, and tap to break taper. Withdraw top nut and remove damper rod.
5. Using appropriate socket wrench, remove lower damper bolt inside axle housing. Remove washer and check for serviceable condition.
6. Remove damper assembly and main spring.
7. Clamp lower leg in vise (protect finish), and firmly pull fork tube to remove seal, top bush, and tube. It may be necessary to "jerk" the tube to drive out the seal and bush.

### RE-ASSEMBLY

#### To Fit the Disc Brake Slider

1. Replacement is a reversal of dismantling. First check the new slider 063547 for cleanliness and lightly oil the internal working surfaces. Check that the damper tube fixing bolt is a perfectly free fit in the thread in the base of the damper unit. This will ensure the damper will not rotate inside the slider as the fixing bolt is finally tightened.
2. Place the oil damper tube sealing washer, using a smear of grease, on the base of the damper, and lower it into position in the counterbore in the fork slider. Locate and fit and tighten the damper tube fixing bolt.
3. Slide the fork tube into the slider, and assemble the top guide bush, oil seal washer and oil seal (lip downwards) onto the slider bore. It may be necessary to lightly drive the top bush and seal separately using a hollow tube to ensure a snug fit in the slider. Refit the threaded collar, tighten and refit the rubber gaiter.
4. Offer the slider assembly up through the lower yoke and engage the taper in the upper yoke.
5. Fill the leg with 150 c.c. of SAE20 oil (5 fluid ounces). This operation is made easier if the slider is slowly "pumped" up and down as the oil is poured to "draw" the fluid down the leg. Engage the top bolt in position through the upper yoke in to the top of the fork tube.
6. Tighten the top bolt to draw the tube taper into the upper yoke. Now unscrew the top bolt, and engage the damper rod, screwing fully home, and locking in position with the damper rod locknut. Refit the top bolt and tighten fully into position. Tighten the lower yoke socket screw.
7. Tighten lower yoke pinch bolt.
8. Turn lower leg so caliper bosses face forward and bolt caliper 063930 loosely to leg with washer under bolt head and under self-lock nut.
9. Assemble master cylinder 063949 to handlebar.

**CAUTION:** Ensure extreme cleanliness from this point on while handling hydraulics.

10. Connect elbow bend of hydraulic hose 063958 to master cylinder, route to avoid pinching or kinking, and attach to caliper.
11. Fit high-performance front fender kit (063706).
12. Fit wheel 063701 into position (with disc between brake pads) and fit axle. Longer axle spacer fits into disc side of wheel 063474/063476.
13. Looking up from beneath, ensure that the disc 063849 lies centrally in cut-away relief in caliper. If not, use shims between caliper and lower leg to secure alignment. Ensure that equal thicknesses of shims are used in both attachment points.
14. Ensure all hydraulic unions are tight and that there is adequate clearance between caliper and spokes.
15. Fill master cylinder with Lockheed Series 329 Brake Fluid, prime and bleed system.
16. Re-align fork legs and check all adjustment points for security.
17. Fit the new front fender.
18. Bed-in brake pads progressively to avoid glazing.

**NOTE:** 1971 and 1972 drum brake model will require the removal of the right Lucas switch cluster. For racing purposes, the entire assembly can be removed; however in this case, the white wire with blue tracer stripe from the coil ballast resistor will have to be connected to a solid white wire in the wiring harness. To retain a kill button, fit Lucas part number 35835 kill button and connect to white/blue wire and a solid white wire in the harness.

#### **KIT NUMBER 10. NORVIL DOUBLE DISC FRONT BRAKE**

- 1—063701 *Front wheel assembly.*
- 2—063849 *Disc.*
- 2—063468 *Hub disc adaptor.*
- 12—014060 *Bolt.*
- 12—024001 *Nut.*
- 24—000011 *Washer.*
- 2—063469 *Disc retainer.*
- 8—063471 *Disc retainer washer.*
- 8—011002 *Disc retainer screw.*
- 2—063476 *Wheel spacer R.H.*
- 2—063474 *Wheel spacer L.H.*
- 1—063950 *Front wheel spindle.*
- 1—063951 *Front wheel spindle washer.*
- 1—063952 *Front wheel spindle nut.*
- 2—063547 *Fork slider.*
- 2—063930 *Caliper.*
- 2—015100 *Bolt.*
- 2—015080 *Bolt.*
- 4—025001 *Nut.*
- 8—035000 *Washer.*
- 1—063949 *Master cylinder.*
- 1—063946 *Hydraulic hose L.H.*
- 1—063947 *Hydraulic hose R.H.*
- 1—063948 *Hydraulic hose master cylinder.*
- 1—063945 *Hydraulic junction block.*
- 1—060459 *Bolt.*
- 2—062361 *Spacer.*
- 1—062240 *Nut.*
- 2—000012 *Washer.*

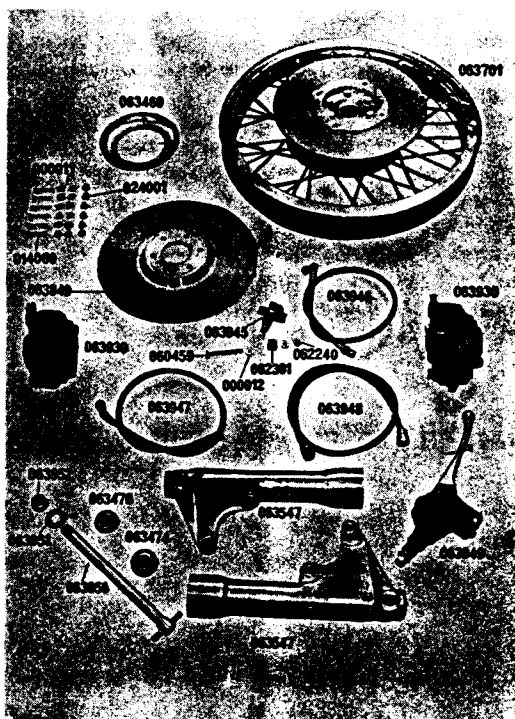

*Illustration 16*

Follow procedures outlined sections "Fitting NORVIL Single Disc" and "Converting NORVIL Single Disc to Double Disc".

**NOTE:** NORVIL disc pads are supplied with a colour-code marking scheme on the pad edge. Ensure that all pads used on a single machine have an identical colour-code.

## KIT NUMBER 11. CONVERTING NORVIL SINGLE DISC BRAKE TO DOUBLE DISC ASSEMBLY

(Must be fitted in conjunction with the racing front fender kit 12).

- 1—063849 Disc.
- 1—063468 Hub — disc adaptor.
- 6—014060 Bolt.
- 6—024001 Nut.
- 12—000011 Washer.
- 1—063469 Disc retainer.
- 4—063471 Disc retainer washer.
- 1—063476 Wheel spacer R.H.
- 1—063474 Wheel spacer L.H.
- 1—063950 Front wheel spindle.
- 1—063951 Front wheel spindle washer.
- 1—063952 Front wheel spindle nut.
- 1—063547 Fork slider.
- 1—063930 Caliper.
- 1—015100 Bolt.
- 1—015080 Bolt.
- 2—025001 Nut.
- 4—035000 Washer.
- 1—063946 Hydraulic hose L.H.
- 1—063947 Hydraulic hose R.H.
- 1—063948 Hydraulic hose — master cylinder.
- 1—063945 Hydraulic junction block.
- 1—060459 Bolt.
- 2—000012 Washer.
- 1—062361 Spacer.
- 1—062240 Nut.

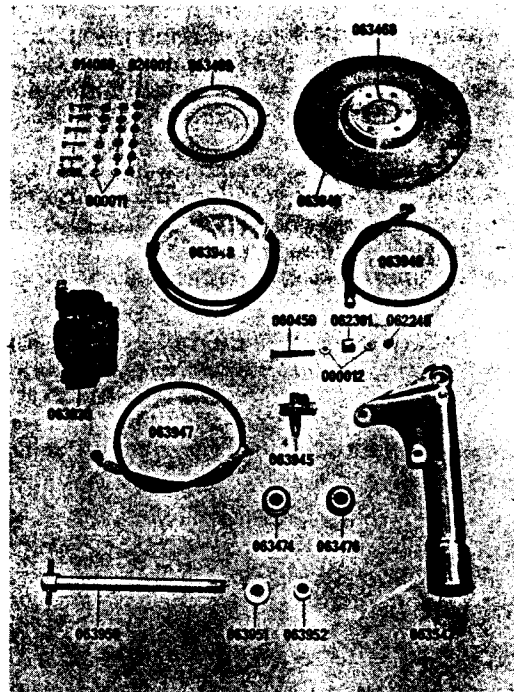

Illustration 17

### FITTING INSTRUCTIONS

1. Remove front wheel and fender.
2. Remove and disassemble left fork leg as outlined in Single Disc conversion.
3. Reassemble fork leg with new lower leg 063547 provided in kit and refit to yokes with caliper boss facing engine.
4. Fit new disc 063849/063468 to wheel hub. Cranked spanners may be needed to reach between the spokes to reach the locknuts 024001.
5. Loosely assemble second caliper 063930 and fit wheel to check for clearance and to ascertain that disc is centred in slot on bottom of caliper.
6. Adjust clearance in slot with shims if necessary.
7. Fit 4-way junction 063945 to lower fork yoke and attach all hydraulic lines. The 4-way adaptor also has provision for a brake light switch for road use. If fitted for racing purposes, blank off fourth hole with plug provided in kit.
8. Ensure all hydraulic fittings are tight, fill master cylinder, and bleed system. Check that all nuts and bolts on entire front fork assembly are secure.
9. Refit NORVIL front mudguard.

### KIT NUMBER 12. FRONT FENDER (750 RACER ONLY)

- 1—063706 Front fender (mudguard).
- 2—063955 Clip.

See Illustration 2

This type of fender is essential when fitting either Norvil single or twin disc type brake.

### FITTING INSTRUCTIONS

1. Remove fender stay-to-fork lower leg bolts. Remove front stay-to-fender bolts and nuts. Remove nuts and washers securing fender centre stay-to-fork legs.
2. Withdraw fender with bottom stay to rear of wheel.
3. On Norton-Lockheed disc brake models, replace nuts and washers to secure hose support bracket to right lower fork leg.
4. Place new fender 063706 in position, identification number to rear end.
5. Open out large hose clamps 063955, place around fork leg below gaiter and round fender securing tabs and tighten to secure fender.